

# DF-220 Rigid

6x2



## Ghandhara DF (Pvt) Ltd.



### Head Office:

F-3, Hub Chowki Road,  
S.I.T.E, Karachi. UAN # 021-111-190-190,  
Tel: 021-32556901-10,  
Fax: 021-32556911-12

### Rawalpindi Office:

Gammon House Plot  
no. 400/2 Peshawar Road, Rawalpindi.  
Ph: 051-5465742  
Fax: 051-5465503

 Dongfeng Pakistan

[www.ghandharadf.com](http://www.ghandharadf.com) 

### Lahore Office:

First Floor, Luban's Arcade,  
Abpara Housing Scheme,  
Near DHA EME Sector,  
Main Canal Road, Lahore 042-35451051



**DONGFENG**

Trucks

# ■ DONGFENG DFL1160BY, DF-220 6x2 Truck Chassis

## Vehicle Weights

G.V.W	27,500 kg
-------	-----------

## Chassis Dimensions (mm)

Overall Chassis Length	7,790
Cab Width	2,460
Cab Height (Unladen)	2,840
Wheel Base	4,500
Front Overhang	1,430
Rear Overhang	1,860
Maximum Speed	100 km/hr
Gradeability	40%

## Frame Dimensions (mm)

Frame width (Front)	860
Frame width (Rear)	860
Frame Section Height	250
Frame Section Width	80

## Clutch

Diameter	395mm (15.5 Inch)
Operating System	Hydraulic control with air booster, pushing.

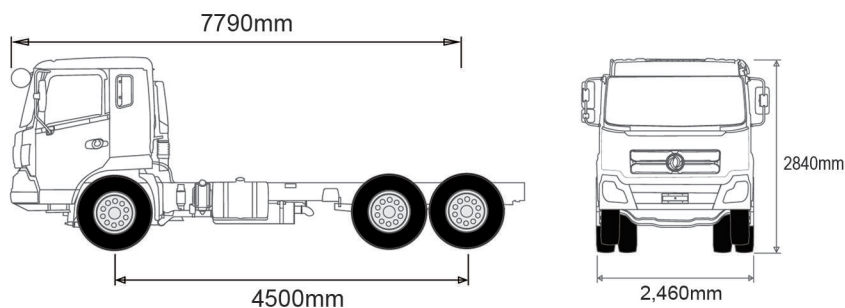

## Engine

Make	Cummins
Model	B220 33
Emission Level	EURO II
Maximum Power	220hp at 2500 rpm
Maximum Torque	670 Nm at 1500 rpm
Displacement (lit)	5,880 CC
Number of Cylinders	6
System	Water cooled, turbocharged, after cooled

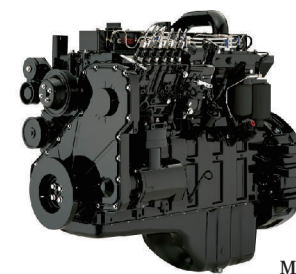

Model : B220 33

## Gear Box / Transmission

Type	8JS85TE-C
Number of Gears	8 forward gears & 1 reverse synchronized



## Axles

Make:	DANA
Front:	Elliot type I beam section
Load Capacity	6 tons
Rear	Single reduction
Load capacity(ton)	10+10 tons
Final Ratio:	5.286

## Suspension

Front:	Leaf spring with shock absorber
Rear:	Leaf spring

## Brake System

Full air brake system, split pneumatic circuit ; parking spring brake acting on rear axles , exhaust brake, Anti-lock braking system ABS.

## Fuel Tank

Type	Steel fuel tank with lockable cap
Capacity	160 Liters

## Cabin

Kingrun one and a half row cab ,forward control type , all welded steel cab of tilt type, mechanical cab tilting, rear mechanical cab suspension adjustable driver's seat, Air Conditioner System.

## Tyres

Front:	Single
Rear:	Dual
Size:	10.00R20

## Battery

Voltage (V) :	24
Battery Capacity (A.h)	140X2

Note : The above mentioned parameters are only for your reference, please check real vehicle referring to actual equipment.

Dealer

